

结构特点 Design features

- 内装、单端面、多弹簧、非平衡型、紧定螺钉结合拨叉传动结构，任意旋向，可承受高扭力驱动；
- 静环可选配SA、SE任一形式。
- Internally mounted, single face, multiple springs, unbalanced structure and driven by screws and claw transmission, any rotation direction, high torque drive.
- Style"SA", "SE" seat ring can be used as mating ring of this rotary unit.

适用范围 Operating limits

- 压力 Pressure: 0~1.2MPa
- 温度 Temperature: -20~180°C(Rubber O-ring)
-40~230°C(PTFE V-Packing)
- 线速度 Speeds: ≤25m/sec

材料 Materials(to DIN24960)

- 旋转环 Rotary Ring: U1、U2、Q1、Q2
- 静止环 Stationary Ring: B、U12、U22、Q2、Q22
- 辅助密封 Auxiliary Seal: P、V、T1
- 弹簧及其他结构件材料 Spring and Other Parts: F、G

介质 Medium

油类、水、盐、非结晶性溶剂、有机溶剂及其它弱腐蚀性溶液。
Oil, water, salt, noncrystalline agent, organic solvents and other weak corrosive fluid.

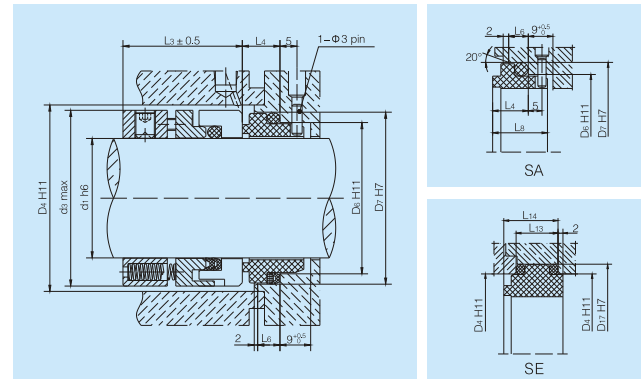

型号 Model	d1	d3	D4	D6	D7	D17	L3	L4	L6	L8	L13	L14	(L3+L4)	(L3+L14)
CN UMS002-20	20	34	36	29	35	42	35	13	5	20	18	23	48	58
CN UMS002-22	22	36	38	31	37	44	35	13	5	20	18	23	48	58
CN UMS002-24	24	38	40	33	39	46	35	13	5	20	18	23	48	58
CN UMS002-25	25	39	41	34	40	47	35	13	5	20	18	23	48	58
CN UMS002-28	28	42	44	37	43	50	35	13	5	20	18	23	48	58
CN UMS002-30	30	44	46	39	45	52	35	13	5	20	18	23	48	58
CN UMS002-32	32	46	48	42	48	54	35	13	5	20	18	23	48	58
CN UMS002-33	33	47	49	42	48	55	35	13	5	20	18	23	48	58
CN UMS002-35	35	49	51	44	50	57	35	13	5	20	18	23	48	58
CN UMS002-38	38	54	58	50	56	64	38	13	5	20	20	25	51	63
CN UMS002-40	40	56	60	52	58	66	38	13	5	20	20	25	51	63
CN UMS002-43	43	59	63	55	61	69	38	13	5	20	20	25	51	63
CN UMS002-45	45	61	65	57	63	71	38	13	5	20	20	25	51	63
CN UMS002-48	48	64	68	60	66	74	38	13	5	20	20	25	51	63
CN UMS002-50	50	66	70	62	68	76	39	13	5	20	20	25	52	64
CN UMS002-53	53	69	73	65	71	79	40	13	5	20	20	25	53	65
CN UMS002-55	55	71	75	67	73	81	40	13	5	20	20	25	53	65
CN UMS002-58	58	76	83	70	79	89	41	16	7	23	22	28	57	69
CN UMS002-60	60	78	85	72	81	91	41	16	7	23	22	28	57	69
CN UMS002-63	63	81	88	75	84	94	41	16	7	23	22	28	57	69
CN UMS002-65	65	83	90	77	86	96	41	16	7	23	22	28	57	69
CN UMS002-68	68	86	93	81	90	99	41	16	7	23	24	30	57	71
CN UMS002-70	70	90	95	83	92	101	42	16	7	23	24	30	58	72
CN UMS002-75	75	95	104	88	97	110	42	16	7	23	24	30	58	72
CN UMS002-80	80	100	109	96	105	115	42	16	7	23	25	31	58	73
CN UMS002-85	85	105	114	101	110	120	43	16	7	23	25	31	59	74
CN UMS002-90	90	110	119	106	115	125	45	16	7	23	25	31	61	76
CN UMS002-95	95	115	124	111	120	130	45	16	7	23	25	31	61	76
CN UMS002-100	100	120	129	116	125	135	45	16	7	23	25	31	61	76